



Made
in EU

FHW
FHW-ECM

High Wall Fan Coil

FHW/FHW-ECM Fan Coil

CONTENTS

FHW Version

• Versions and Main Components	Page 3
• Dimension, Weight, Water content	Page 4
• Technical features	Page 6
• Working conditions	Page 7
• Emissions	Page 8
• Water side pressure drop	Page 10
• Accessories	Page 10
• Control operations	Page 11
• Wall electronic controls	Page 12
• Electronic control accessories	Page 15
• Controls and units	Page 16

FHW-ECM Serie

• Versions and Main Components	Page 17
• Dimension, Weight, Water content	Page 18
• Technical features	Page 20
• Working conditions	Page 21
• Emissions	Page 22
• Models with electric heater	Page 24
• Water side pressure drop	Page 25
• Accessories	Page 25
• ECM configuration	Page 26
• Controls and units T and MB versions	Page 27

FHW / FHW-ECM Serie

• Controls and units T version	Page 28
• Controls and units MB version	Page 29
• Management system for a network of units	Page 34
• Accessories	Page 37

INTRODUCTION

FHW is the high wall fan coil unit designed and manufactured in Italy, in 4 sizes and many different models.

FHW is easy to install like a standard fan coil: without decreasing the emission and without any extra frame, 2 way or 3 way valves and condensate pump can be mounted into the casing.

The modern and appealing design of the unit in RAL 9003 colour allows the use of **FHW** in any environment.

FHW is available with standard AC motors or low energy EC motors and in the following versions: with wired wall control, infra-red remote control, MB electronic board for Modbus management and electric heating coil.

The units are for 2 pipe installations only.

All the **FHW** models perform very low electric consumption and extremely quite sound levels according to the request of today's new projects.

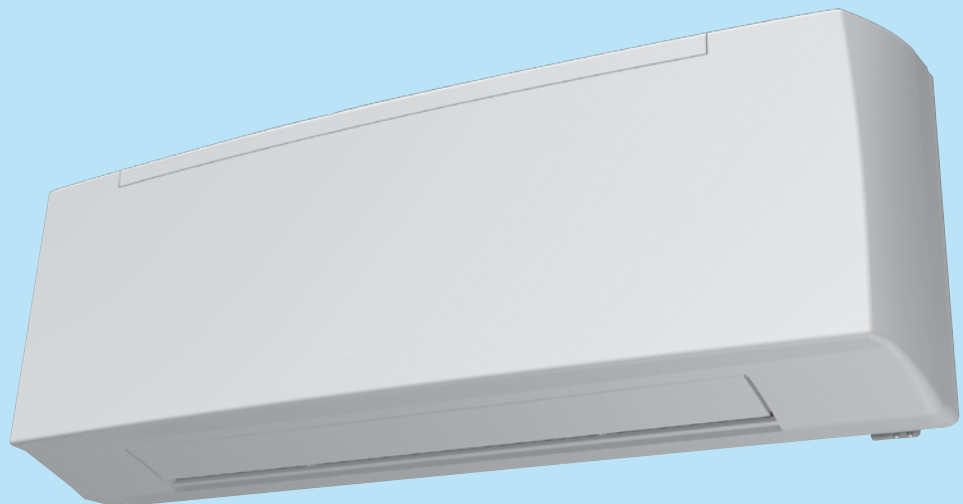

FHW/FHW

Versions and Main components

FHW MODELS WITHOUT ELECTRIC HEATER

All versions are available without valves, with 2 way valve or with 3 way valve fitted in the unit. There are four sizes available in the following versions:

FHW	without infra-red remote control and without valve
FHW-2V	without infra-red remote control with fitted 2 way valve
FHW-3V	without infra-red remote control with fitted 3 way valve

FHW-T	with infra-red remote control and without valve
FHW-T-2V	with infra-red remote control with fitted 2 way valve
FHW-T-3V	with infra-red remote control with fitted 3 way valve

FHW-MB	with MB electronic board and without valve
FHW-MB-2V	with MB electronic board with fitted 2 way valve
FHW-MB-3V	with MB electronic board with fitted 3 way valve

CONSTRUCTIONAL FEATURES OF THE MAIN COMPONENTS

Casing

Made of auto-extinguishing ABS UL94 HB plastic with high specifications and great resistance to aging. The diffusion flap is adjusted manually in FHW version, with remote control in FHW-T version and with T-MB control in FHW-MB version.

Air Filter

Washable-regenerable synthetic filter, readily accessible.

Fan Assembly

Made of plastic tangential fan.

Electric motor

Electronic motor with three phase permanent magnet brushless electronic motor that is controlled with reconstructed current according to a BLAC sinusoidal wave. The inverter board that controls the motor operation is powered by 230 Volt, single-phase and, with a switching system, it generates a three-phase frequency modulated, wave form power supply. The electric power supply required for the machine is therefore single-phase with voltage of 230-240V and frequency of 50-60Hz.

Heat exchange coil

It is manufactured from drawn copper tube and the aluminium fins are mechanically bonded onto the tube by an expansion process. The coil has two 1/2 inch BSP internal connections and 1/8 inch BSP air vent and drain. The heat exchanger is not suitable for use in corrosive atmosphere or in environments where aluminium may be subject to corrosion. The connections are on the left side facing the unit only.

Condensate Collection Tray

Made from polypropylene; the outside diameter of the condensate discharge pipe is 16mm.

Installation template

A cardboard installation template is supplied with every unit to help the mounting on the wall.

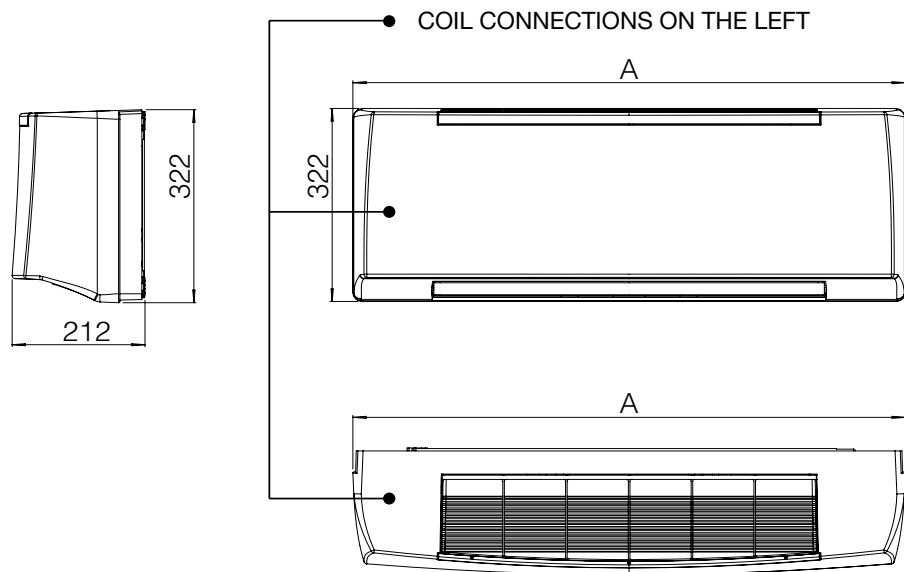

MOUNTING DIMENSIONS

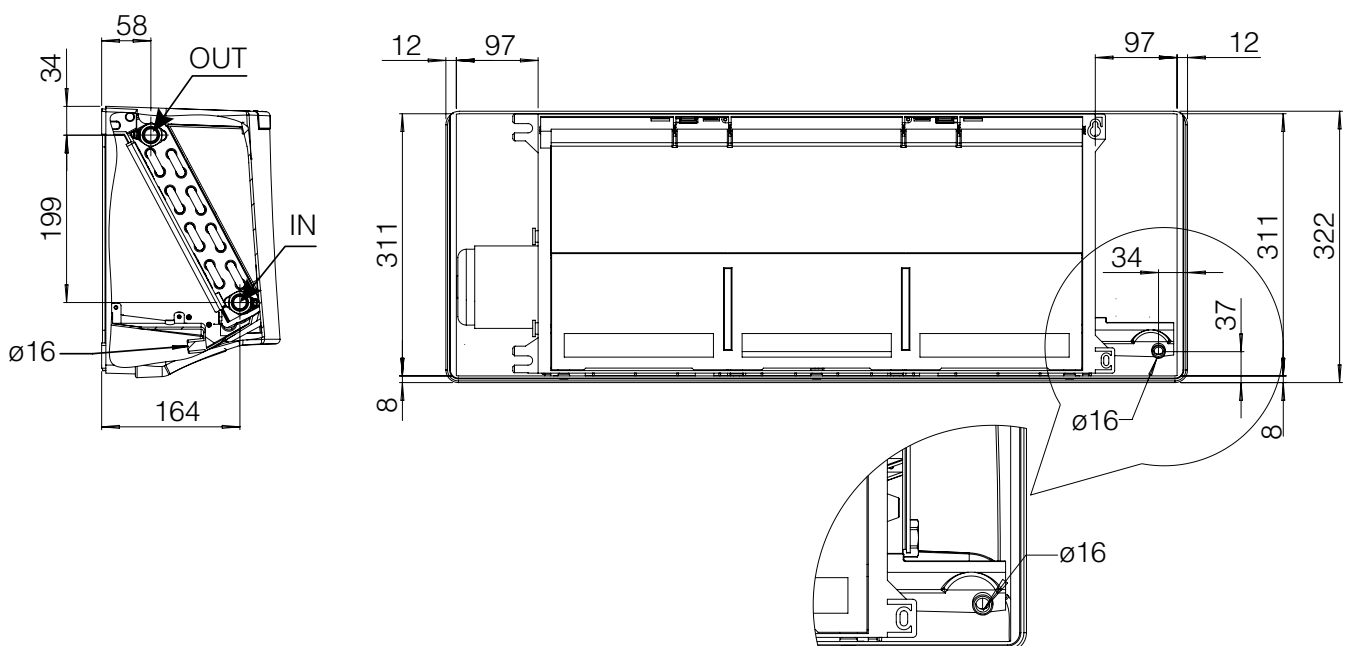
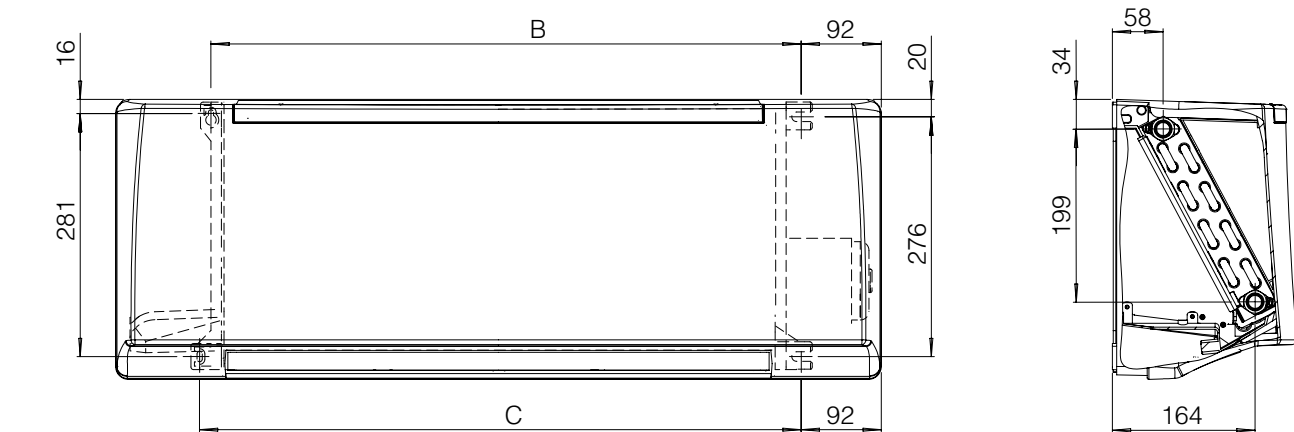

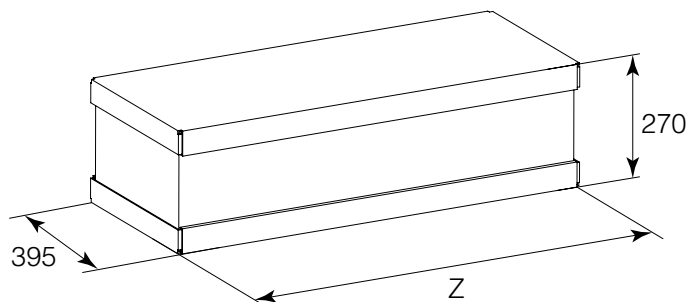

DIMENSION (mm)

<i>MODEL</i>	FHW 1	FHW 2	FHW 3	FHW 4
A	880	880	1185	1185
B	678	678	983	983
C	691	691	996	996
Z	950	950	1255	1255

WEIGHT (kg)

<i>MODEL</i>	<i>Weight packed unit</i>				<i>Weight unpacked unit</i>			
	FHW 1	FHW 2	FHW 3	FHW 4	FHW 1	FHW 2	FHW 3	FHW 4
<i>without valve</i>	12	12	16	16	10	10	13	13
<i>with valve</i>	13	13	17	17	11	11	14	14

WATER CONTENT (l)

<i>MODEL</i>	FHW 1	FHW 2	FHW 3	FHW 4
<i>litres</i>	0,85	0,85	1,28	1,28

2-pipe units

The following standard rating conditions are used:

COOLING (summer operation)

Entering air temperature: + 27°C d.b. / + 19°C w.b.

Water temperature: + 7°C E.W.T. / + 12°C L.W.T.

HEATING (winter operation)

Entering air temperature: + 20°C

Water temperature: + 50°C E.W.T.

Water flow rate as for the cooling conditions

MODEL		FHW 1						FHW 2					
		1	2	3	4	5	6	1	2	3	4	5	6
Speed		MIN	MED		MAX		MIN		MED		MAX		
Air flow	m ³ /h	205	270	340	375	470	500	250	305	365	400	480	545
Cooling total emission	kW	1,24	1,50	1,76	1,87	2,15	2,23	1,43	1,63	1,84	1,95	2,18	2,35
Cooling sensible emission	kW	0,92	1,14	1,36	1,46	1,72	1,80	1,07	1,25	1,43	1,53	1,75	1,92
Heating	kW	1,60	2,00	2,39	2,58	3,04	3,17	1,88	2,20	2,39	2,70	3,09	3,38
ΔP Cooling	kPa	4,8	6,8	9,0	10,1	13,0	13,9	6,2	7,9	9,8	10,9	13,3	15,2
ΔP Heating	kPa	3,7	5,5	7,2	8,3	10,6	10,8	4,8	6,4	7,2	8,5	10,9	12,5
Fan	W	12	14	17	18	24	30	12	14	18	20	24	32
Sound power	Lw	35	41	46	48	52	53	39	43	47	49	53	55
Sound pressure (*)	Lp	26	32	37	39	43	44	30	34	38	40	44	46

MODEL		FHW 3						FHW 4					
		1	2	3	4	5	6	1	2	3	4	5	6
Speed		MIN	MED		MAX			MIN		MED		MAX	
Air flow	m ³ /h	280	375	480	545	730	780	300	440	500	610	675	790
Cooling total emission	kW	1,89	2,32	2,78	3,03	3,63	3,78	1,99	2,62	2,86	3,26	3,46	3,81
Cooling sensible emission	kW	1,35	1,69	2,06	2,27	2,81	2,95	1,43	1,93	2,12	2,47	2,66	2,98
Heating	kW	2,26	2,84	3,49	3,86	4,79	5,03	2,40	3,26	3,61	4,20	4,53	5,07
ΔP Cooling	kPa	11,2	16,2	22,5	26,2	36,4	39,1	12,3	20,2	23,6	29,9	33,4	39,7
ΔP Heating	kPa	8,7	12,6	17,7	21,2	29,3	31,9	9,7	15,9	19,1	23,7	27,2	31,5
Fan	W	16	21	26	29	38	46	17	23	27	32	35	48
Sound power	Lw	35	40	45	48	55	57	36	43	46	51	54	57
Sound pressure (*)	Lp	26	31	36	39	46	48	27	34	37	42	45	48

MIN-MED-MAX = Standard connected speeds.

(*) = The sound pressure levels are 9 dB(A) lower than the sound power levels and apply to the reverberant field of a 100 m³ room and a reverberation time of 0.5 sec.

Working conditions

WORKING CONDITIONS

Max. entering water temperature..... + 70 °C

MIn. entering water temperature..... + 6 °C

for entering water temperatures below + 6°C, contact technical department

Max. rated pressure 1000 kPa (10 bars)

Installation height (m)

MODEL	FHW 1 ÷ 4
Minimum	2
Maximum	3

Motor electrical data (max. absorption)

MODEL		FHW 1	FHW 2	FHW 3	FHW 4
230/1 50Hz	W	30	32	46	48
	A	0,16	0,16	0,23	0,23

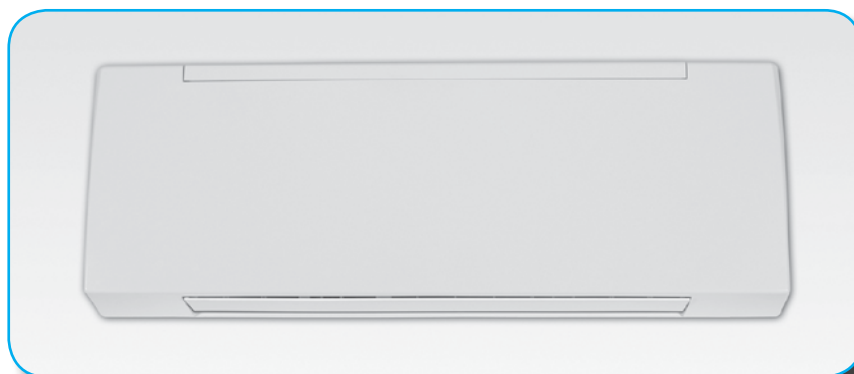

Cooling emission

Entering air temperature: +25°C - Relative Humidity: 50%

Model	Speed	WT: 7/12 °C					WT: 8/13 °C				WT: 10/15 °C				WT: 12/17 °C			
		Qv m³/h	Pc kW	Ps kW	Qw l/h	Dp(c) kPa	Pc kW	Ps kW	Qw l/h	Dp(c) kPa	Pc kW	Ps kW	Qw l/h	Dp(c) kPa	Pc kW	Ps kW	Qw l/h	Dp(c) kPa
FHW 1	VI	500	1,90	1,63	328	10,4	1,69	1,58	290	8,3	1,31	1,31	225	6,9	1,09	1,09	188	3,7
	V	470	1,83	1,55	315	9,7	1,62	1,50	279	7,8	1,26	1,26	216	6,4	1,03	1,03	177	3,4
	IV MAX	375	1,59	1,31	274	7,6	1,41	1,26	242	6,0	1,08	1,08	186	4,9	0,83	0,83	143	2,3
	III	340	1,49	1,22	257	6,7	1,32	1,17	227	5,3	1,01	1,01	173	4,3	0,76	0,76	130	1,9
	I MIN	270	1,28	1,02	220	5,1	1,12	0,97	193	4,0	0,86	0,86	147	3,2	0,64	0,64	109	1,4
FHW 2	VI	545	2,00	1,73	345	11,4	1,78	1,68	306	9,2	1,39	1,39	238	7,7	1,17	1,17	201	4,2
	V MAX	480	1,86	1,58	319	9,9	1,64	1,53	283	8,0	1,27	1,27	219	6,6	1,05	1,05	181	3,5
	IV	400	1,66	1,38	286	8,1	1,47	1,33	253	6,5	1,13	1,13	194	5,3	0,88	0,88	152	2,5
	III MED	365	1,56	1,29	269	7,3	1,38	1,24	238	5,8	1,06	1,06	182	4,7	0,81	0,81	139	2,2
	I	305	1,39	1,12	239	5,9	1,22	1,07	210	4,7	0,93	0,93	160	3,8	0,70	0,70	120	1,7
FHW 3	VI	780	3,23	2,66	556	29,5	2,87	2,57	493	23,7	2,22	2,22	382	17,8	1,69	1,69	290	9,0
	V	730	3,10	2,53	534	27,4	2,75	2,44	474	22,0	2,13	2,13	366	16,5	1,61	1,61	277	8,2
	IV MAX	545	2,58	2,04	444	19,7	2,28	1,95	392	15,7	1,74	1,74	300	11,5	1,31	1,31	225	5,6
	III	480	2,37	1,84	407	16,9	2,09	1,76	359	13,4	1,59	1,59	274	9,8	1,19	1,19	204	4,8
	I MIN	375	1,98	1,50	340	12,2	1,74	1,43	299	9,6	1,32	1,29	226	6,9	0,97	0,97	167	3,3
FHW 4	VI MAX	790	3,26	2,68	560	29,9	2,89	2,59	497	24,0	2,24	2,24	385	18,1	1,70	1,70	293	9,1
	V	675	2,96	2,39	509	25,1	2,62	2,30	450	20,1	2,02	2,02	347	15,0	1,52	1,52	262	7,5
	IV MED	610	2,78	2,22	478	22,5	2,46	2,13	423	18,0	1,89	1,89	325	13,3	1,42	1,42	244	6,6
	III	500	2,44	1,90	419	17,7	2,15	1,82	370	14,1	1,64	1,64	282	10,3	1,22	1,22	211	5,0
	I	440	2,23	1,72	384	15,2	1,97	1,64	338	12,0	1,49	1,49	257	8,7	1,11	1,11	191	4,2

Heating emission

Entering air temperature: +20°C

Model	Speed	WT: 70/60 °C				WT: 60/50 °C			WT: 50/40 °C			WT: 50/45 °C			WT: 45/40 °C		
		Qv m³/h	Ph kW	Qw l/h	Dp(c) kPa	Ph kW	Qw l/h	Dp(c) kPa	Ph kW	Qw l/h	Dp(c) kPa	Ph kW	Qw l/h	Dp(c) kPa	Ph kW	Qw l/h	Dp(c) kPa
FHW 1	VI	500	5,46	470	15,0	4,22	363	9,7	2,96	254	5,3	3,32	571	22,6	2,71	466	15,9
	V	470	5,22	449	13,8	4,03	346	9,0	2,83	244	4,9	3,17	545	20,8	2,58	444	14,7
	IV MAX	375	4,40	378	10,1	3,40	293	6,6	2,40	206	3,6	2,67	459	15,3	2,18	375	10,8
	III	340	4,07	350	8,8	3,16	271	5,8	2,23	191	3,2	2,48	427	13,3	2,02	347	9,4
	I MIN	270	3,39	292	6,4	2,63	226	4,2	1,86	160	2,3	2,06	354	9,6	1,68	289	6,8
FHW 2	VI	545	5,82	514	16,8	4,49	397	10,9	3,15	278	6,0	3,54	609	25,4	2,88	495	17,8
	V MAX	480	5,30	468	14,2	4,09	361	9,2	2,87	254	5,0	3,22	554	21,4	2,62	451	15,1
	IV	400	4,62	408	11,1	3,57	315	7,2	2,52	222	4,0	2,81	483	16,7	2,29	394	11,8
	III MED	365	4,31	380	9,8	3,33	294	6,4	2,35	207	3,5	2,62	451	14,7	2,13	366	10,4
	I	305	3,74	329	7,6	2,90	255	4,9	2,05	180	2,7	2,27	390	11,4	1,85	318	8,1
FHW 3	VI	780	8,54	754	36,7	6,61	585	24,0	4,68	414	13,4	5,19	893	55,5	4,24	729	39,2
	V	730	8,13	717	33,6	6,31	556	22,0	4,46	394	12,3	4,94	850	50,8	4,04	695	35,9
	IV MAX	545	6,51	573	22,5	5,06	446	14,8	3,59	317	8,3	3,95	679	34,0	3,23	556	24,1
	III	480	5,89	518	18,8	4,58	403	12,4	3,26	288	7,0	3,57	614	28,4	2,93	504	20,1
	I MIN	375	4,78	420	12,9	3,72	327	8,5	2,66	234	4,8	2,90	499	19,4	2,37	408	13,8
FHW 4	VI MAX	790	8,62	761	37,4	6,68	590	24,4	4,72	418	13,6	5,24	901	56,5	4,28	736	39,9
	V	675	7,66	676	30,2	5,95	525	19,8	4,21	373	11,0	4,66	802	45,7	3,80	654	32,3
	IV MED	610	7,11	627	26,4	5,52	487	17,3	3,92	346	9,7	4,32	743	39,8	3,53	607	28,2
	III	500	6,08	535	19,9	4,73	417	13,1	3,37	297	7,4	3,69	635	30,0	3,02	519	21,3
	I	440	5,49	483	16,6	4,28	376	10,9	3,05	269	6,2	3,34	574	25,0	2,73	470	17,8

Legend

- WT** = Water temperature **Speed** = Fan speed
- Ph** = Emission **MAX** = High speed
- Pc** = Cooling Total emission **MED** = Medium speed
- Ps** = Cooling Sensible emission **MIN** = Low speed
- Qw** = Water flow **Qv** = Air flow
- Dp(c)** = Water side pressure drop

FHW MODELS WITH ELECTRIC HEATER

All versions are available without valves, with 2 way valve or with 3 way valve fitted in the unit. There are four sizes available in the following versions:

FHW-E without infra-red remote control and without valve
FHW-E-2V without infra-red remote control with fitted 2 way valve
FHW-E-3V without infra-red remote control with fitted 3 way valve

FHW-T-E with infra-red remote control and without valve
FHW-T-E-2V with infra-red remote control with fitted 2 way valve
FHW-T-E-3V with infra-red remote control with fitted 3 way valve

FHW-MB-E with MB electronic board and without valve
FHW-MB-E-2V with MB electronic board with fitted 2 way valve
FHW-MB-E-3V with MB electronic board with fitted 3 way valve

According to the control provided, the electrical heater can be used as an alternative or as a supplement to the hot water; in the first case controls such as WM-T can be chosen, in the second case controls such as WM-TQR.

The heater is hermetically sealed and supplied inside the battery pipes and therefore can be only factory mounted.

The electric heaters of the **FHW** units are single phase 230V supply.

The electric heater is fitted with a overheat protection.

The unit is fitted with two safety thermostats:

- one thermostat with manual reset;
- one thermostat with automatic reset.

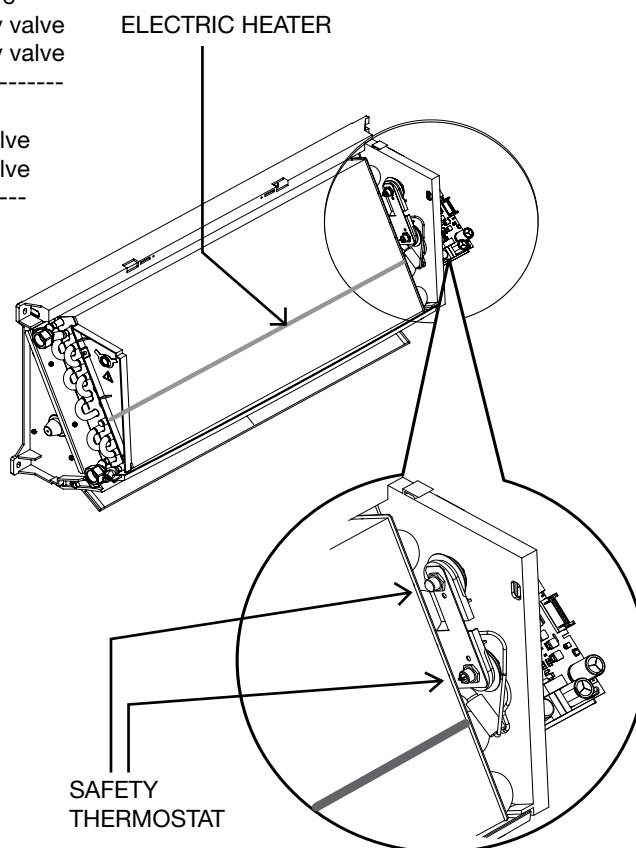

Main technical characteristics

Model	FHW 1	FHW 2	FHW 3	FHW 4
Nominal installed power	1000 Watt	1000 Watt	1500 Watt	1500 Watt
Nominal power voltage	230V ~	230V ~	230V ~	230V ~
Number and section of connecting wires	3 x 1,5mm ²	3 x 1,5mm ²	3 x 1,5mm ²	3 x 1,5mm ²
Current input	4,5 A	4,5 A	7 A	7 A
Recommended fuse (Type gG) for overload protection	6 A	6 A	8 A	8 A

FHW operating limits with electric heater

Max. ambient temperature for **FHW** with electric coil in heating mode: 25°C.

Coil pressure drop

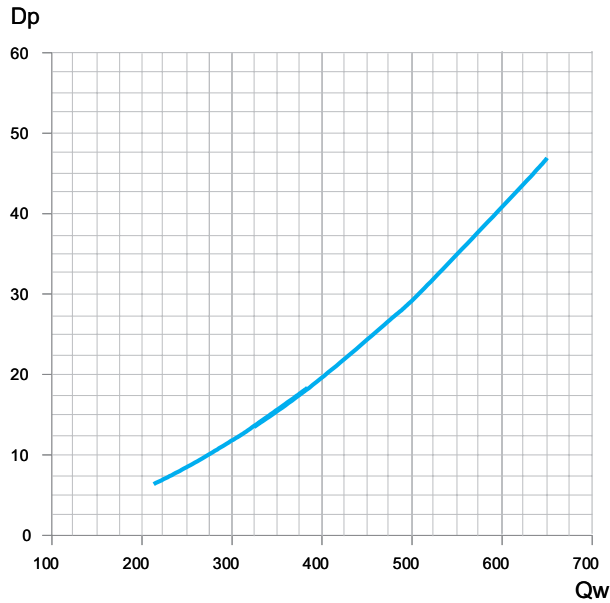

Pressure drop for mean water temperature of 10°C; for different temperatures multiply the pressure drop figure by the K correction factors in the table.

°C	20	30	40	50	60	70	80
K	0,94	0,90	0,86	0,82	0,78	0,74	0,70

Valves pressure drop

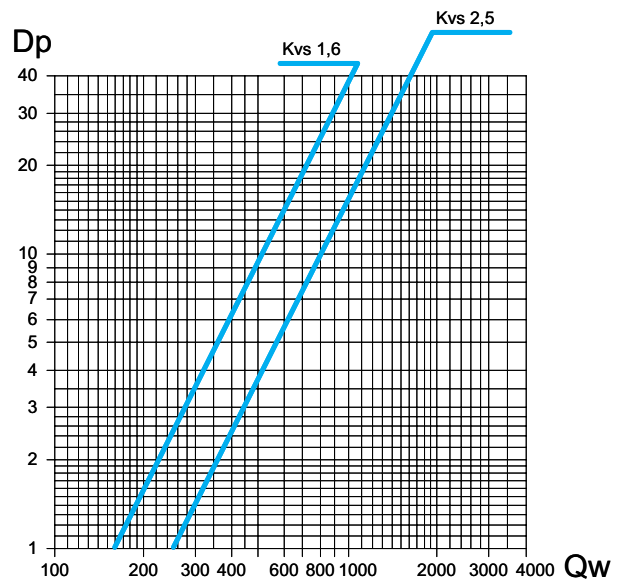

Legend

Qw = water flow (l/h)

Dp = pressure drop (kPa)

Accessories

FV3S 3 way valve

mod.	Valve			Code
	DN	(Ø)	Kvs	Not Fitted
1 - 2	15	1/2"	1,6	9025321H
3 - 4	20	3/4"	2,5	9025323H

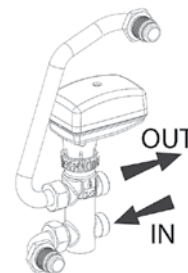

FV2S 2 way valve

mod.	Valve			Code
	DN	(Ø)	Kvs	Not Fitted
1 - 2	15	1/2"	1,6	9025311H
3 - 4	20	3/4"	2,5	9025313H

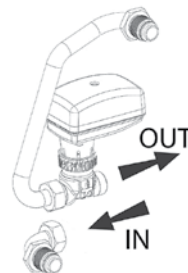

PCF condensate drain pump

	Fitted on the unit	Not fitted on the unit
ID	PCF-M	PCF-S
Code	9025319	9025309

Height for vertical flow (m)	Water flow (l/h) depending on the length of horizontal flow	
	5m	10 m
1	7,6	7,2
2	5,6	5,2
3	4,0	3,7
4	3,2	2,9

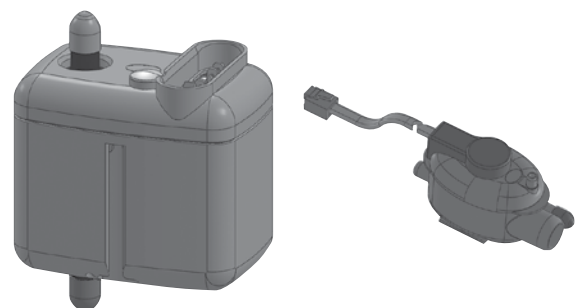

Control operations

Electrical diagrams are shown on the installation, use and maintenance manual

CONTROL OPERATIONS	CONTROL IDENTIFICATION	WM-3V	WM-T	WM-TQR	TMO-503-SV2	T2T
ON-OFF switch		●	●	●	●	●
ON-OFF electric heater				●		
Manual 3 speed switch		●	●	●	●	●
Manual/Automatic 3 speed selection					●	
Summer/Winter switch			●	●	●	●
Remote centralized Summer/Winter switch or by an automatic change-over fitted on the water pipe				●		
Room thermostat for fan control (ON-OFF)			●	●	●	●
Room thermostat for 1 valve control			●	●	●	●
Simultaneous thermostatic control of the valves and fan			●	●	●	●
Room thermostat for chilled water valve (SUMMER) and electric heater (WINTER) control (in winter only the heater is working)			●	●	●	
Installation of electronic low temperature CUT-OUT thermostat (NTC)				●	○	
Installation of bimetallic low temperature CUT-OUT thermostat (TMM)			●			
CONTROL CODES		9066642	9066630E	9066631E	9060173	9060174

ID	Code
WM-3V	9066642



Dimensions: 75x75x30 mm

- Manual 3 speed switch.
- Without thermostatic control.
- It can not control the valves.

ID	Code
WM-T	9066630E



Dimensions: 135x86x31 mm

- ON-OFF switch.
- Manual 3 speed switch.
- Manual Summer/Winter switch.
- Electronic room thermostat for fan control (ON-OFF).
- Electronic room thermostat for valve control (ON-OFF) (the fan keeps working).
- It allows to control the low temperature cut-out thermostat (TMM).
- It allows to control the chilled water valve (ON-OFF) and the electric heater (BEL).

ID	Code
WM-TQR	9066631E



Dimensions: 135x86x31 mm

- ON-OFF switch.
- Manual 3 speed switch.
- Manual Summer/Winter switch.
- Electric heater activation button.
- Electronic room thermostat for fan control (ON-OFF).
- Electronic room thermostat for valve control (ON-OFF).
- Simultaneous thermostatic control of the valves and fan.
- It allows to control the low temperature cut-out thermostat (NTC).
- It allows to control the water valves (ON-OFF) and the electric heater managed as main heating element or as an integration element.
- It allows to control the summer/winter cycle with a centralized and remote switch or with an automatic change-over fitted on the water pipe (for 2-tube installations only).
- Energy saving function.

ID	Code
TMO-503-SV2	9060172



Dimensions: 118x87x8 mm

The TMO-503-SV2 control for fan coils with valves, is designed to be installed in a 503 wall box. The control is supplied integral with the external frame, but it is possible to use frames of the most known brand on the market (BTicino, Vimar, AVE, Gewiss).

- Manual or automatic speed switch.
- Manual Summer/Winter switch.
- Electronic thermostat for valve(s) control (ON-OFF).
- Simultaneous thermostatic control on the valves and fan (ON-OFF).
- It allows to control the low temperature cut-out thermostat (included with the control).

ID	Code
T2T	9060174



Dimensions: 128x75x25 mm

- ON-OFF switch.
- 3 speed switch.
- Manual Summer/Winter switch.
- Electronic thermostat for fan control.
- Thermostatic control on the valve and continuous fan operation.
- Simultaneous thermostatic control on the valves and fan.
- Cannot be used with SEL-CVP speed switch (master-slave).

Speed switches - FHW version

<i>ID</i>	<i>Code</i>
SEL-CVP	9025302

- Speed switch (slave).
- It allows to control up to 8 units with only one centralized thermostat using one speed switch for each unit.
- For controls: WM-T, WM-TQR and TMO-503-SV2.



Electronic control accessories

NTC low temperature cut-out thermostat

<i>ID</i>	<i>Code</i>
<i>NTC</i>	<i>3021090</i>



To be fitted between the coil fins.

When connecting the control, the NTC probe cable must be separated from the power supply wires.

To be used with the following controls: WM-TQR.

It stops the fan when the water temperature is lower than 28°C and it starts the fan when is higher than 33°C.

TMM low temperature cut-out thermostat

<i>ID</i>	<i>Code</i>
<i>TMM</i>	<i>9053048</i>

To be installed in contact with the hot water circuit.

To be used with the following controls only: WM-T.

For units working on heating only.

It stops the fan when the water temperature is lower than 30°C and it starts the fan when is higher than 38°C.

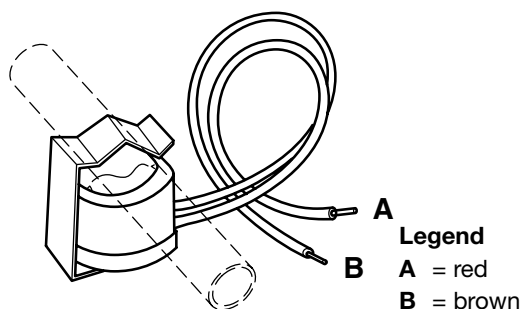

Legend

A = red

B = brown

Change-Over CH 15-25

<i>ID</i>	<i>Code</i>
<i>CH 15 -25</i>	<i>9053049</i>

Automatic summer/winter switch to be installed in contact with the water circuit.

Not to be used with 2 way valve.

To be used with the following controls only: WM-TQR.

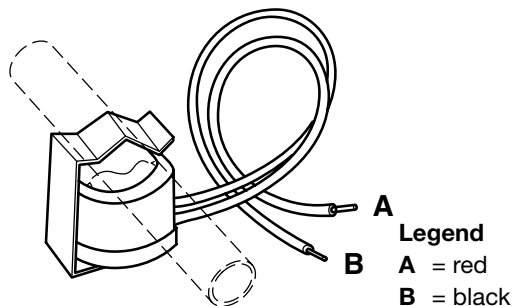

Legend

A = red

B = black

All the **FHW** units can be supplied in **T version** and in **MB version**.

- The **T version** includes the infra-red remote control that allows the management of a single unit (the units can not be controlled in a network).
- The **MB version** includes a wide range of controls, including the **infra-red remote control** (optional extra), which allows to manage one single unit or several units by using the Modbus RTU - RS 485 communication protocol. Units can be managed according to the Master/Slave logic (up to 20 units) or by supervisory controls. The system consists in a **MB** power board (mounted on models FHW-MB) and a series of controls, such as the **T-MB** wall mounted control, the **RT03** infra-red remote control, the **PSM-DI** multifunction control and the **NET** supervisory program.



T-MB WALL CONTROL

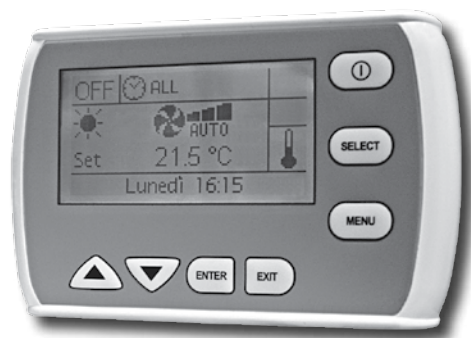

PSM-DI MULTIFUNCTION CONTROL



RT03 INFRA-RED REMOTE CONTROL



NET SOFTWARE



All the controls for the T and MB versions and their functions are described in detail from page 28.

Versions and Main components

FHW-ECM MODELS WITHOUT ELECTRIC HEATER

All versions are available without valves, with 2 way valve or with 3 way valve fitted in the unit.
 There are four sizes available in the following versions:

FHW-ECM	without infra-red remote control and without valve
FHW-ECM-2V	without infra-red remote control with fitted 2 way valve
FHW-ECM-3V	without infra-red remote control with fitted 3 way valve

FHW-ECM-T	with infra-red remote control and without valve
FHW-ECM-T-2V	with infra-red remote control with fitted 2 way valve
FHW-ECM-T-3V	with infra-red remote control with fitted 3 way valve

FHW-ECM-MB	with MB electronic board and without valve
FHW-ECM-MB-2V	with MB electronic board with fitted 2 way valve
FHW-ECM-MB-3V	with MB electronic board with fitted 3 way valve

CONSTRUCTIONAL FEATURES OF THE MAIN COMPONENTS

Casing

Made of auto-extinguishing ABS UL94 HB plastic with high specifications and great resistance to aging.
 The diffusion flap is adjusted manually in FHW-ECM version, with remote control in FHW-ECM-T version and with T-MB control in FHW-ECM-MB version.

Air Filter

Washable-regenerable synthetic filter, readily accessible.

Fan Assembly

Made of plastic tangential fan.

Electronic motor

Electronic motor WITH three phase permanent magnet brushless controlled with reconstructed current according to a BLAC sinusoidal wave.
 The inverter board that controls the motor operation is powered by 230 Volt, single-phase and, with a switching system, it generates a three-phase frequency modulated, wave form power supply.
 The electric power supply required for the machine is therefore single-phase with voltage of 230-240V and frequency of 50-60Hz.

Heat exchange coil

It is manufactured from drawn copper tube and the aluminium fins are mechanically bonded onto the tube by an expansion process. The coil has two 1/2 inch BSP internal connections and 1/8 inch BSP air vent and drain.
 The heat exchanger is not suitable for use in corrosive atmosphere or in environments where aluminium may be subject to corrosion.
 The connections are on the left side facing the unit only.

Condensate Collection Tray

Made from polypropylene; the outside diameter of the condensate discharge pipe is 16mm.

Installation template

A cardboard installation template is supplied with every unit to help the mounting on the wall.

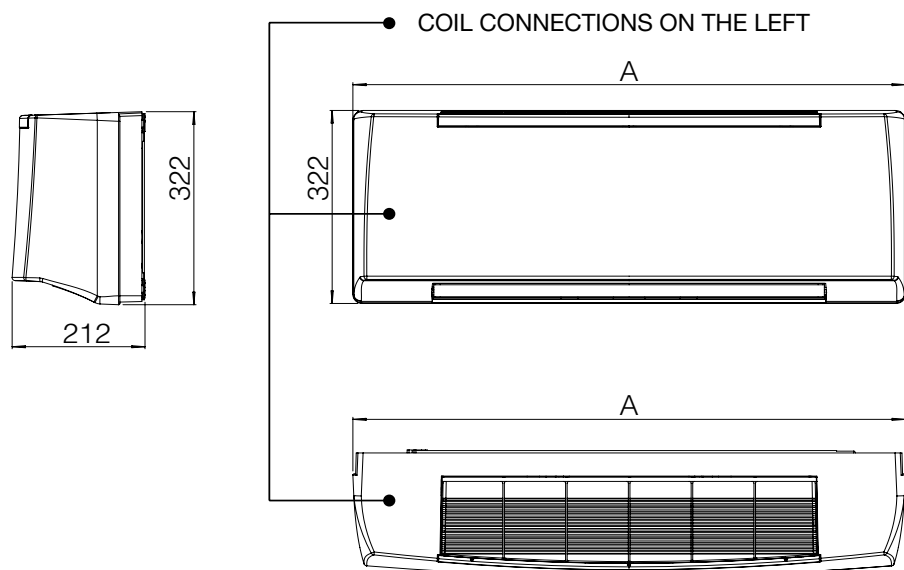

MOUNTING DIMENSIONS

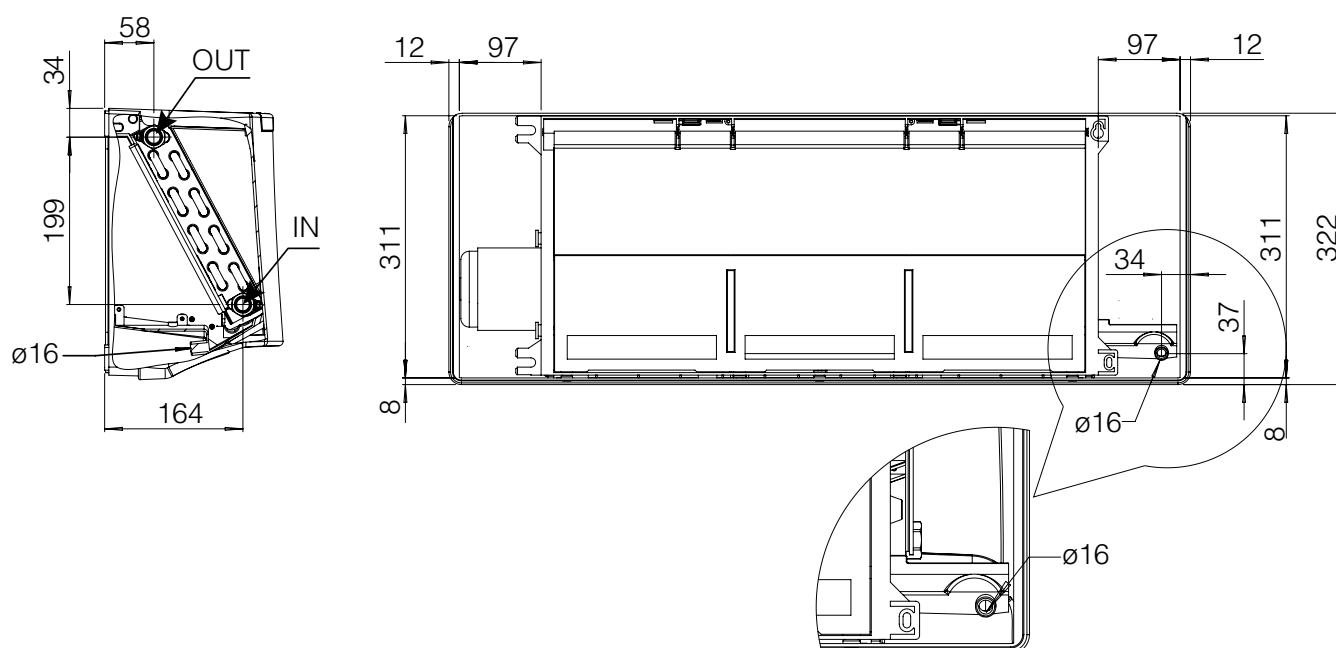
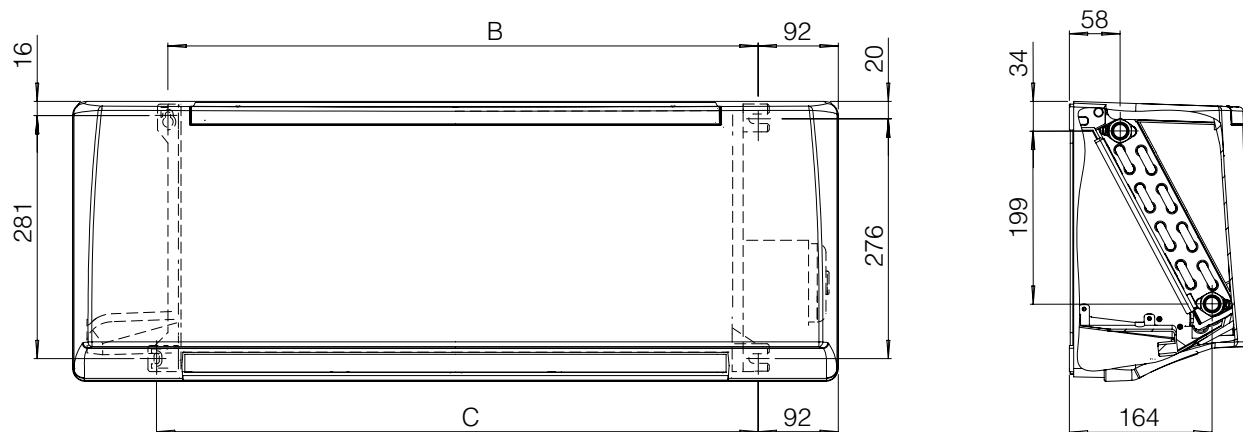

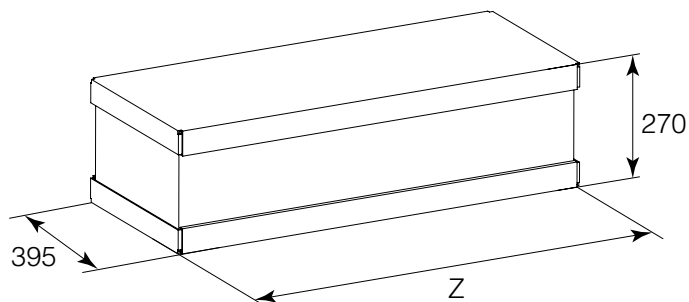

DIMENSION (mm)

<i>MODEL</i>	FHW-ECM 1	FHW-ECM 2	FHW-ECM 3	FHW-ECM 4
A	880	880	1185	1185
B	678	678	983	983
C	691	691	996	996
Z	950	950	1255	1255

WEIGHT (kg)

<i>MODEL</i>	<i>Weight packed unit</i>				<i>Weight unpacked unit</i>			
	FHW-ECM 1	FHW-ECM 2	FHW-ECM 3	FHW-ECM 4	FHW-ECM 1	FHW-ECM 2	FHW-ECM 3	FHW-ECM 4
<i>without valve</i>	12	12	16	16	10	10	13	13
<i>with valve</i>	13	13	17	17	11	11	14	14

WATER CONTENT (l)

<i>MODEL</i>	FHW-ECM 1	FHW-ECM 2	FHW-ECM 3	FHW-ECM 4
<i>litres</i>	0,85	0,85	1,28	1,28

2-pipe units

The following standard rating conditions are used:

COOLING (summer operation)

Entering air temperature: + 27°C d.b. / + 19°C w.b.

Water temperature: + 7°C E.W.T. / + 12°C L.W.T.

HEATING (winter operation)

Entering air temperature: + 20°C

Water temperature: + 50°C E.W.T.

Water flow rate as for the cooling conditions

MODEL		FHW-ECM 1					FHW-ECM 2				
		1	3	5	7,5	10	1	3	5	7,5	10
Speed		MIN		MED		MAX	MIN		MED		MAX
Air flow	m ³ /h	190	240	290	355	415	260	315	375	440	510
Cooling total emission	kW	1,17	1,39	1,58	1,81	2,00	1,47	1,67	1,87	2,07	2,26
Cooling sensible emission	kW	0,86	1,04	1,20	1,40	1,57	1,10	1,28	1,46	1,64	1,83
Heating	kW	1,50	1,82	2,12	2,48	2,78	1,94	2,25	2,58	2,90	3,23
ΔP Cooling	kPa	5,0	6,3	7,7	9,5	11,2	6,9	8,4	10,1	11,8	13,7
ΔP Heating	kPa	4,2	5,4	6,5	8,2	9,3	5,6	6,9	8,5	9,7	11,6
Fan	W	6	7	9	11	15	7	9	12	16	21
Sound power	Lw	35	39	46	48	52	40	44	47	51	55
Sound pressure (*)	Lp	26	30	37	39	43	31	35	38	42	46

MODEL		FHW-ECM 3					FHW-ECM 4				
		1	3	5	7,5	10	1	3	5	7,5	10
Speed		MIN		MED		MAX	MIN		MED		MAX
Air flow	m ³ /h	270	345	420	520	620	375	465	550	665	770
Cooling total emission	kW	1,83	2,20	2,53	2,93	3,29	2,34	2,72	3,05	3,43	3,75
Cooling sensible emission	kW	1,31	1,60	1,86	2,19	2,50	1,70	2,01	2,29	2,63	2,92
Heating	kW	2,20	2,69	3,15	3,72	4,25	2,87	3,41	3,88	4,48	4,99
ΔP Cooling	kPa	10,7	14,8	19,0	24,8	30,4	16,5	21,6	26,6	32,9	38,7
ΔP Heating	kPa	8,5	11,7	15,1	19,9	24,2	12,6	17,2	21,2	26,6	31,4
Fan	W	6	8	11	15	20	9	12	16	22	30
Sound power	Lw	37	42	45	49	53	43	46	49	53	57
Sound pressure (*)	Lp	28	33	36	40	44	34	37	40	44	48

MIN-MED-MAX = Standard connected speeds.

(*) = The sound pressure levels are 9 dB(A) lower than the sound power levels and apply to the reverberant field of a 100 m³ room and a reverberation time of 0.5 sec.

WORKING CONDITIONS

Max. entering water temperature..... + 70 °C
 Min. entering water temperature..... + 6 °C
for entering water temperatures below + 6°C, contact technical department
 Max. rated pressure 1000 kPa (10 bars)

Installation height (m)

MODEL	FHW-ECM 1 ÷ 4
Minimum	2
Maximum	3

Motor electrical data (max. absorption)

MODEL		FHW-ECM 1	FHW-ECM 2	FHW-ECM 3	FHW-ECM 4
230/1 50Hz	W	15	21	20	30
	A	0,14	0,19	0,18	0,26

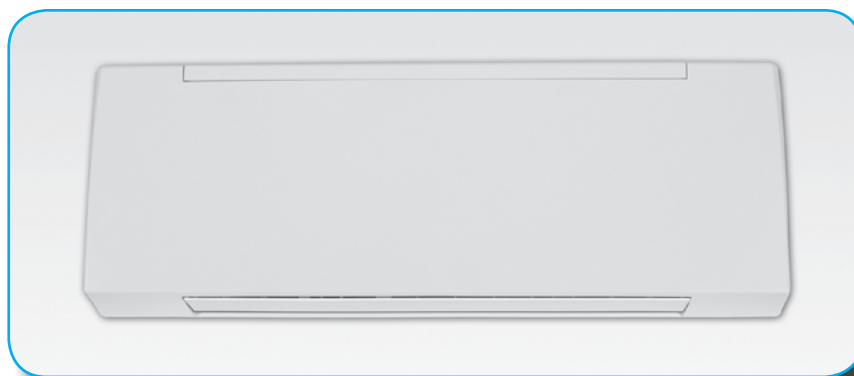

Cooling emission

Entering air temperature: +25°C - Relative Humidity: 50%

Model	Vdc	WT: 7/12 °C					WT: 8/13 °C					WT: 10/15 °C				WT: 12/17 °C			
		Qv	Pc	Ps	Qw	Dp(c)	Pc	Ps	Qw	Dp(c)	Pc	Ps	Qw	Dp(c)	Pc	Ps	Qw	Dp(c)	
		m³/h	kW	kW	l/h	kPa	kW	kW	l/h	kPa	kW	kW	l/h	kPa	kW	kW	l/h	kPa	
FHW-ECM 1	10 MAX	415	1,70	1,42	292	8,5	1,50	1,37	258	6,7	1,16	1,16	199	4,2	0,91	0,91	157	2,7	
	7,5	355	1,54	1,26	264	7,1	1,36	1,21	233	5,6	1,04	1,04	179	3,4	0,79	0,79	135	2,1	
	5 MED	290	1,34	1,08	231	5,5	1,18	1,03	203	4,4	0,90	0,90	155	2,7	0,67	0,67	116	1,6	
	3	240	1,18	0,93	202	4,4	1,03	0,88	178	3,4	0,78	0,78	135	2,1	0,58	0,58	100	1,2	
	1 MIN	190	1,00	0,77	171	3,2	0,87	0,73	150	2,5	0,66	0,66	113	1,5	0,49	0,49	83	0,9	
FHW-ECM 2	10 MAX	510	1,93	1,65	331	10,6	1,71	1,60	294	8,5	1,33	1,33	228	5,3	1,11	1,11	191	3,9	
	7,5	440	1,76	1,48	303	9,0	1,56	1,43	268	7,2	1,20	1,20	207	4,5	0,97	0,97	166	3,0	
	5 MED	375	1,59	1,31	274	7,5	1,41	1,26	242	6,0	1,08	1,08	186	3,7	0,83	0,83	143	2,3	
	3	315	1,42	1,15	244	6,1	1,25	1,10	215	4,9	0,95	0,95	164	3,0	0,72	0,72	123	1,7	
	1 MIN	260	1,24	0,99	214	4,8	1,10	0,94	188	3,8	0,83	0,83	143	2,3	0,62	0,62	106	1,3	
FHW-ECM 3	10 MAX	620	2,81	2,25	483	22,9	2,48	2,15	427	18,3	1,91	1,91	328	11,3	1,44	1,44	247	6,7	
	7,5	520	2,50	1,96	430	18,6	2,21	1,88	380	14,8	1,69	1,69	290	9,0	1,26	1,26	217	5,3	
	5 MED	420	2,16	1,66	371	14,3	1,90	1,58	328	11,3	1,44	1,43	248	6,8	1,07	1,07	185	4,0	
	3	345	1,88	1,42	323	11,1	1,65	1,35	284	8,8	1,25	1,21	215	5,3	0,92	0,92	159	3,0	
	1 MIN	270	1,57	1,17	270	8,1	1,38	1,10	237	6,4	1,04	0,98	178	3,8	0,76	0,76	131	2,1	
FHW-ECM 4	10 MAX	770	3,21	2,63	551	29,1	2,85	2,54	490	23,4	2,20	2,20	379	14,6	1,67	1,67	288	8,8	
	7,5	665	2,93	2,37	504	24,8	2,59	2,27	446	19,8	2,00	2,00	344	12,3	1,51	1,51	259	7,3	
	5 MED	550	2,60	2,05	447	19,9	2,29	1,96	395	15,9	1,76	1,76	302	9,7	1,32	1,32	226	5,7	
	3	465	2,32	1,80	399	16,2	2,04	1,71	351	12,9	1,56	1,56	268	7,8	1,16	1,16	199	4,6	
	1 MIN	375	2,00	1,52	343	12,4	1,76	1,44	302	9,8	1,33	1,30	229	5,9	0,98	0,98	169	3,4	

Heating emission

Entering air temperature: +20°C

Model	Vdc	WT: 70/60 °C			WT: 60/50 °C			WT: 50/40 °C			WT: 50/45 °C			WT: 45/40 °C			
		Qv	Ph	Qw	Dp(c)	Ph	Qw	Dp(c)	Ph	Qw	Dp(c)	Ph	Qw	Dp(c)	Ph	Qw	Dp(c)
		m³/h	kW	l/h	kPa	kW	l/h	kPa	kW	l/h	kPa	kW	l/h	kPa	kW	l/h	kPa
FHW-ECM 1	10 MAX	415	4,75	409	11,7	3,67	316	7,6	2,58	222	4,2	2,89	497	17,6	2,35	405	12,4
	7,5	355	4,22	363	9,4	3,26	281	6,1	2,30	198	3,4	2,56	441	14,2	2,09	359	10,0
	5 MED	290	3,59	309	7,0	2,79	240	4,6	1,97	169	2,6	2,18	375	10,6	1,78	306	7,5
	3	240	3,08	265	5,3	2,39	206	3,5	1,70	146	2,0	1,87	322	8,1	1,53	263	5,7
	1 MIN	190	2,54	219	3,8	1,98	170	2,5	1,41	121	1,4	1,54	265	5,7	1,26	217	4,0
FHW-ECM 2	10 MAX	510	5,55	477	15,4	4,28	368	10,0	3,00	258	5,5	3,37	580	23,3	2,74	472	16,3
	7,5	440	4,97	427	12,6	3,83	330	8,2	2,70	232	4,5	3,02	519	19,1	2,46	423	13,4
	5 MED	375	4,40	378	10,1	3,40	293	6,6	2,40	206	3,6	2,67	460	15,3	2,18	375	10,8
	3	315	3,84	330	7,9	2,97	256	5,2	2,10	181	2,9	2,33	401	12,0	1,90	327	8,4
	1 MIN	260	3,29	283	6,0	2,55	220	3,9	1,81	156	2,2	2,00	344	9,1	1,63	281	6,4
FHW-ECM 3	10 MAX	620	7,19	618	26,9	5,58	480	17,7	3,96	340	9,9	4,36	751	40,6	3,57	614	28,8
	7,5	520	6,27	539	21,1	4,87	419	13,8	3,47	298	7,8	3,81	655	31,8	3,11	536	22,5
	5 MED	420	5,29	455	15,5	4,12	354	10,2	2,94	253	5,8	3,21	553	23,4	2,63	452	16,6
	3	345	4,51	388	11,6	3,52	303	7,7	2,52	216	4,4	2,74	471	17,5	2,24	386	12,5
	1 MIN	270	3,68	316	8,1	2,87	247	5,4	2,06	177	3,1	2,23	383	12,1	1,83	315	8,7
FHW-ECM 4	10 MAX	770	8,45	727	36,1	6,55	564	23,6	4,64	399	13,1	5,14	884	54,5	4,20	722	38,6
	7,5	665	7,58	652	29,6	5,88	506	19,4	4,17	359	10,8	4,61	792	44,7	3,76	647	31,7
	5 MED	550	6,55	563	22,8	5,09	438	15,0	3,62	311	8,4	3,98	685	34,4	3,26	560	24,4
	3	465	5,74	494	18,0	4,47	384	11,8	3,18	274	6,7	3,49	600	27,1	2,85	491	19,3
	1 MIN	375	4,83	415	13,2	3,76	324	8,7	2,69	231	4,9	2,93	504	19,8	2,40	413	14,1

Legend

WT = Water temperature	Vdc = Inverter power
Ph = Emission	MAX = High speed
Pc = Cooling Total emission	MED = Medium speed
Ps = Cooling Sensible emission	MIN = Low speed
Qw = Water flow	Qv = Air flow
Dp(c) = Water side pressure drop	

FHW-ECM MODELS WITH ELECTRIC HEATER

All versions are available without valves, with 2 way valve or with 3 way valve fitted in the unit.
There are four sizes available in the following versions:

FHW-ECM-E without infra-red remote control and without valve
FHW-ECM-E-2V without infra-red remote control with fitted 2 way valve
FHW-ECM-E-3V without infra-red remote control with fitted 3 way valve

FHW-ECM-T-E with infra-red remote control and without valve
FHW-ECM-T-E-2V with infra-red remote control with fitted 2 way valve
FHW-ECM-T-E-3V with infra-red remote control with fitted 3 way valve

FHW-ECM-MB-E with MB electronic board and without valve
FHW-ECM-MB-E-2V with MB electronic board with fitted 2 way valve
FHW-ECM-MB-E-3V with MB electronic board with fitted 3 way valve

The heater is hermetically sealed and supplied inside the battery pipes and therefore can be only factory mounted.

The electric heaters of the **FHW-ECM** units are single phase 230V supply.

The electric heater is fitted with a overheat protection.

The unit is fitted with two safety thermostats:

- one thermostat with manual reset;
- one thermostat with automatic reset.

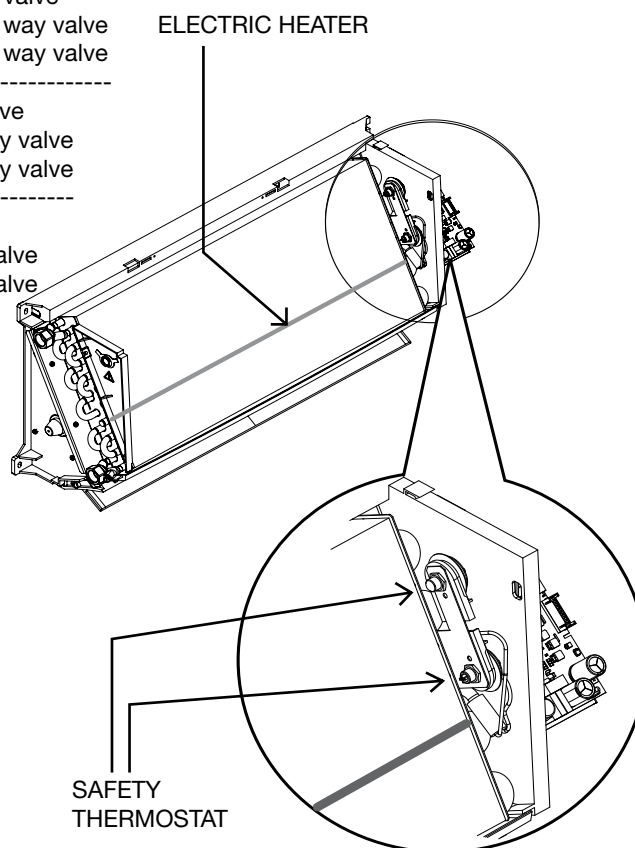

Main technical characteristics

Model	FHW-ECM 1	FHW-ECM 2	FHW-ECM 3	FHW-ECM 4
Nominal installed power	1000 Watt	1000 Watt	1500 Watt	1500 Watt
Nominal power voltage	230V ~	230V ~	230V ~	230V ~
Number and section of connecting wires	3 x 1,5mm ²	3 x 1,5mm ²	3 x 1,5mm ²	3 x 1,5mm ²
Current input	4,5 A	4,5 A	7 A	7 A
Recommended fuse (Type gG) for overload protection	6 A	6 A	8 A	8 A

FHW-ECM operating limits with electric heater

Max. ambient temperature for **FHW-ECM** with electric coil in heating mode: 25°C.

Coil pressure drop

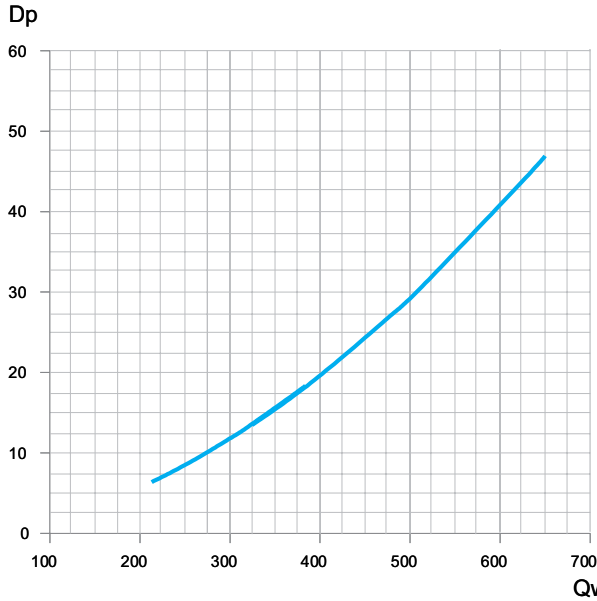

Pressure drop for mean water temperature of 10°C; for different temperatures multiply the pressure drop figure by the K correction factors in the table.

°C	20	30	40	50	60	70	80
K	0,94	0,90	0,86	0,82	0,78	0,74	0,70

Valves pressure drop

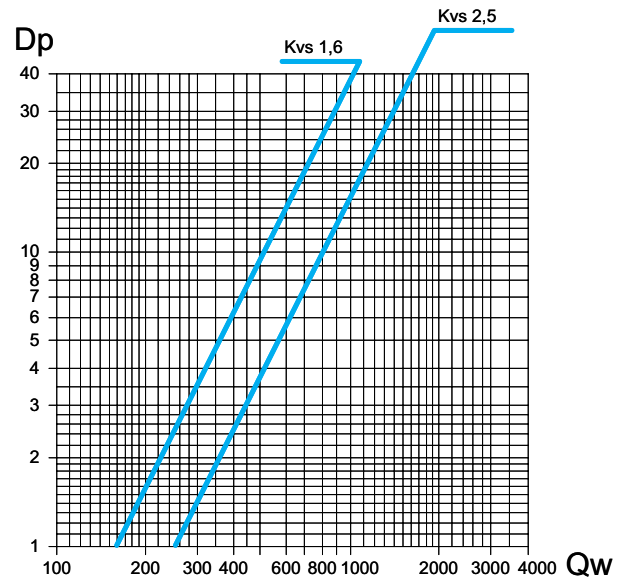

Legend
Qw = water flow (l/h)
Dp = pressure drop (kPa)

Accessories

FV3S 3 way valve

mod.	Valve			Code
	DN	(Ø)	Kvs	Not Fitted
1 - 2	15	1/2"	1,6	9025321H
3 - 4	20	3/4"	2,5	9025323H

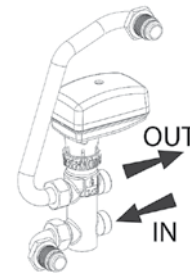

FV2S 2 way valve

mod.	Valve			Code
	DN	(Ø)	Kvs	Not Fitted
1 - 2	15	1/2"	1,6	9025311H
3 - 4	20	3/4"	2,5	9025313H

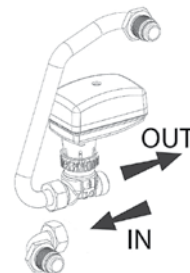

PCF condensate drain pump

	Fitted on the unit	Not fitted on the unit
ID	PCF-M	PCF-S
Code	9025319	9025309

Height for vertical flow (m)	Water flow (l/h) depending on the length of horizontal flow	
	5m	10 m
1	7,6	7,2
2	5,6	5,2
3	4,0	3,7
4	3,2	2,9

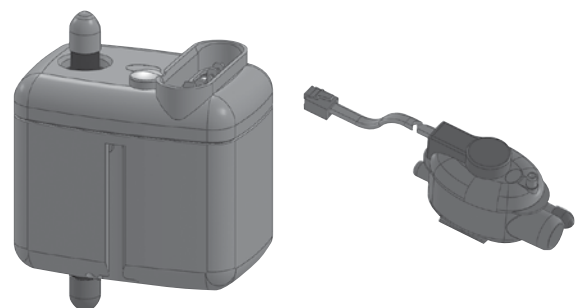

For this fan coil configuration, the 1-10 Vdc signal, which controls the inverter, must be supplied by a controller with the following signal specifications:

- Impedance < 100 Ohm;
- Maximum speed 10 Vdc;
- Fan OFF with V < 1 Vdc;
- Signal 1 - 10 Vdc.

FHW-ECM electric wiring diagram

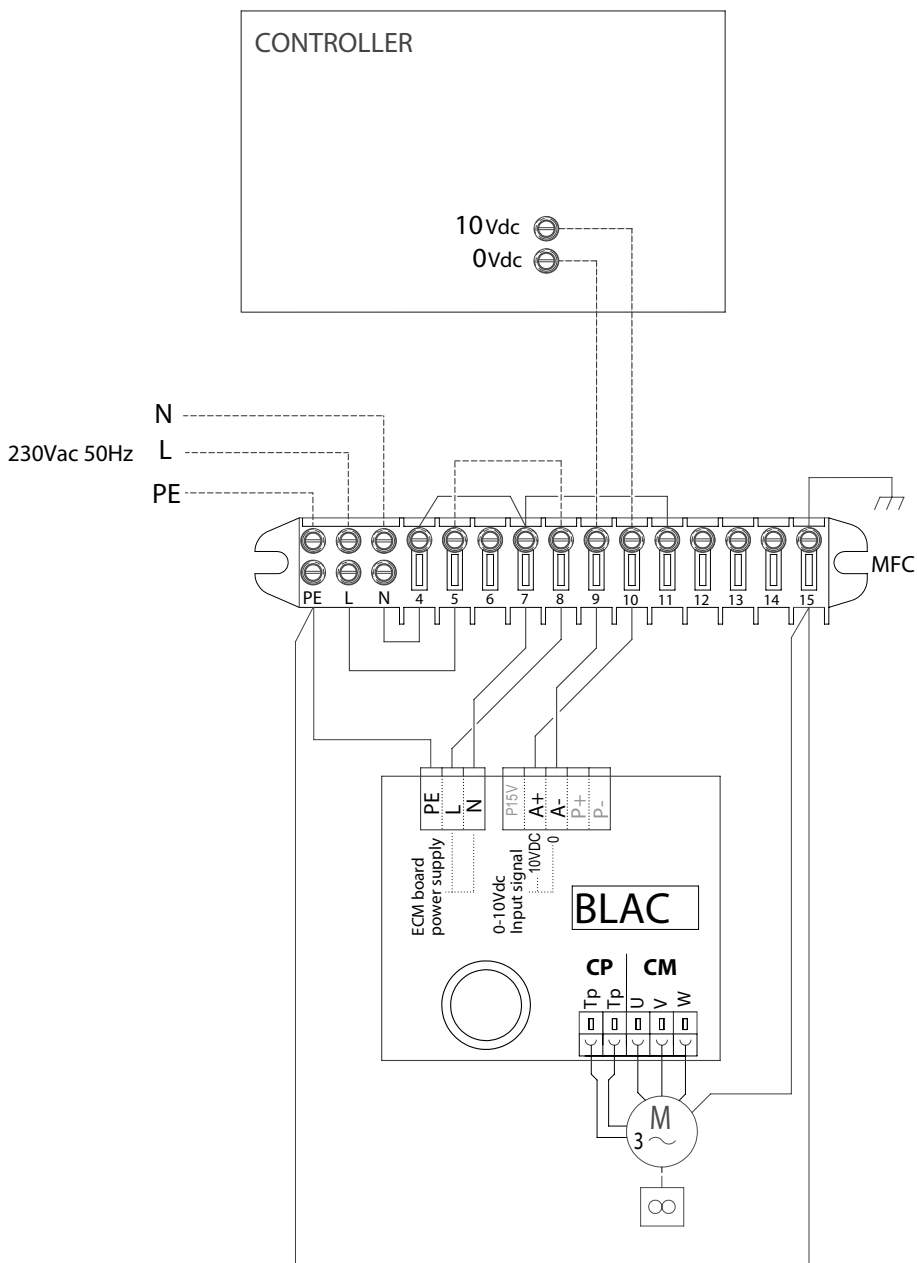

Legend	
CONTROLLER	= Controller
BLAC	= Inverter circuit board
M	= Brushless electronic motor
CM	= Motor fan connection
CP	= Motor fan thermal protection connection

All the **FHW-ECM** units can be supplied in **T version** and in **MB version**.

- The **T version** includes the infra-red remote control that allows the management of a single unit (the units can not be controlled in a network).
- The **MB version** includes a wide range of controls, including the **infra-red remote control** (optional extra), which allows to manage one single unit or several units by using the Modbus RTU - RS 485 communication protocol. Units can be managed according to the Master/Slave logic (up to 20 units) or by supervisory controls. The system consists in a **MB** power board (mounted on models FHW-ECM-MB) and a series of controls, such as the **T-MB** wall mounted control, the **RT03** infra-red remote control, the **PSM-DI** multifunction control and the **NET** supervisory program.



T-MB WALL CONTROL

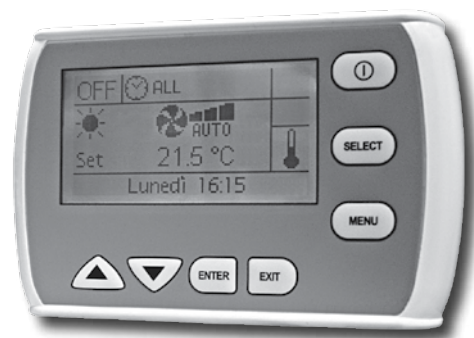

PSM-DI MULTIFUNCTION CONTROL



RT03 INFRA-RED REMOTE CONTROL



NET SOFTWARE



All the controls for the T and MB versions and their functions are described in detail from page 28.

Stand alone units: the infra-red remote control can control one unit only

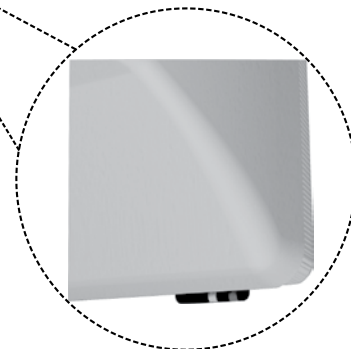

RT03 INFRA-RED REMOTE CONTROL

The electronic board, mounted as per standard on the **FHW-T** and **FHW-ECM-T**, is set to carry out different functions and adjustment modes, in order to meet the installation requirements. These modes are selected by setting the configuration dip switches on the board.

- Fan ON/OFF thermostatic control.
- Valve ON/OFF thermostatic control and continuous ventilation.
- Valve and simultaneous ventilation ON/OFF thermostatic control.
- Fan operation control depending on the coil temperature (cut-out T3 probe fitted), which can be activated only in heating mode or heating and cooling mode.
- Automatic switch of the operating mode by means of T2 water probe (optional).
- Seasonal switch by means of remote contact.
- ON/OFF of the fan coil by means of the remote contact (window or clock contact).
- Electric heater control

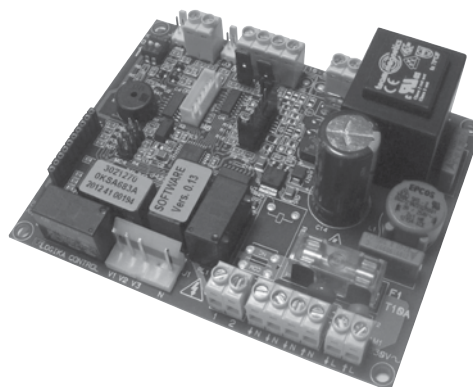

By activating the cut-out T3 probe function, the fan is stopped in winter when the coil temperature is lower than 32°C and started when the temperature reaches 36°C. In summer mode, the fan stops when the temperature inside the coil exceeds 22°C and starts when it drops below 18°C.

The infra-red remote control allows setting by a remote position the fan coil operation parameters.

The **RT03** infra-red remote control features the following functions:

- Switch the appliance ON and OFF.
- Temperature set.
- Set the fan speed (low, medium, high or autofan).
- Set the operation mode (fan only, cooling, heating).
- Time setting.
- 24 hours ON/OFF program.

These units can be controlled with RT03 infrared control and with T-MB or PSM-DI wall controls and they can be managed by a supervising control system



T-MB WALL CONTROL

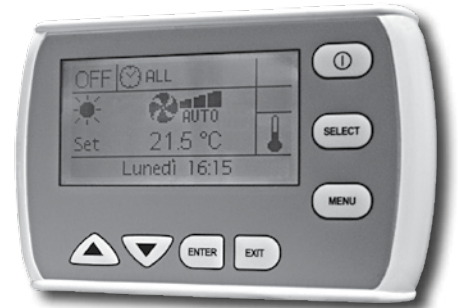

PSM-DI MULTIFUNCTION CONTROL

RT03 INFRA-RED REMOTE CONTROL

The **MB** electronic board, mounted as per standard on the **FHW-MB** and **FHW-ECM-MB**, is set to carry out different functions and adjustment modes, in order to meet the installation requirements. These modes are selected by setting the configuration dip switches on the board.

- Fan ON/OFF thermostatic control.
- Valve ON/OFF thermostatic control and continuous ventilation.
- Valve and simultaneous ventilation ON/OFF thermostatic control.
- Fan operation control depending on the coil temperature (cut-out T3 probe fitted), which can be activated only in heating mode or heating and cooling mode.
- Automatic switch of the operating mode by means of T2 water probe (optional).
- Seasonal switch by means of remote contact.
- ON/OFF of the fan coil by means of the remote contact (window or clock contact).
- Electric heater control

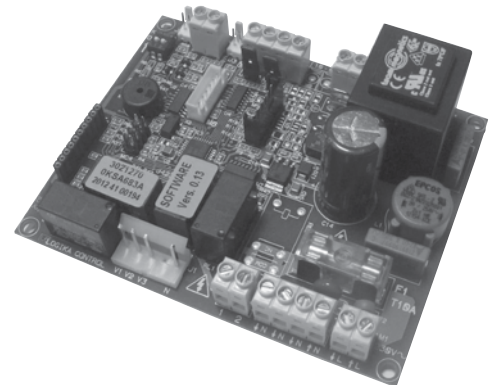

By activating the cut-out T3 probe function, the fan is stopped in winter when the coil temperature is lower than 32°C and started when the temperature reaches 36°C. In summer mode, the fan stops when the temperature inside the coil exceeds 22°C and starts when it drops below 18°C.

The following connections are located on the power board:

- Receiver for infra-red remote control.
- **T-MB** wall control.
- RS 485 serial connection to manage several fan coils in Master/Slave configuration or to create a supervision network.

T-MB wall control

Description	ID	Code
Wall control (to be used with MB board only)	T-MB	9066331E

Wall control with display that allows controlling one or more units in Master/Slave mode. The control is equipped with internal sensor to detect the room temperature, which can be defined as a priority compared to the return air sensor on the fan coil.



Dimensions : 110x72x25 mm

The **T-MB** control features the following functions:

- Switch the appliance ON and OFF.
- Temperature set.
- Modify the set point (when used as a +/- 3° variation of the set point configured from NET supervisory program or PSM-DI).
- Set the fan speed (low, medium, high or autofan).
- Set the operation mode (fan only, cooling, heating).
- Time setting.
- Weekly ON/OFF program.
- Display and change of the fan coil operation parameters.

RT03 infra-red remote control

Description	ID	Code
<i>RT03 infra-red remote control with receiver supplied with separate packaging (to be used with MB board only)</i>	RS-RT03-F	9025301
<i>RT03 infra-red remote control supplied with separate packaging (to be used with MB board only)</i>	RT03	3021203
<i>Receiver for RT03 infra-red remote control supplied with separate packaging (to be used with MB board only)</i>	RS-F	9025300

The infra-red remote control allows setting by a remote position the fan coil operation parameters.

The **RT03** infra-red remote control features the following functions:

- Switch the appliance ON and OFF.
- Temperature set.
- Set the fan speed (low, medium, high or autofan).
- Set the operation mode (fan only, cooling, heating).
- Time setting.
- 24 hours ON/OFF program.



ID	Code
RT03	3021203

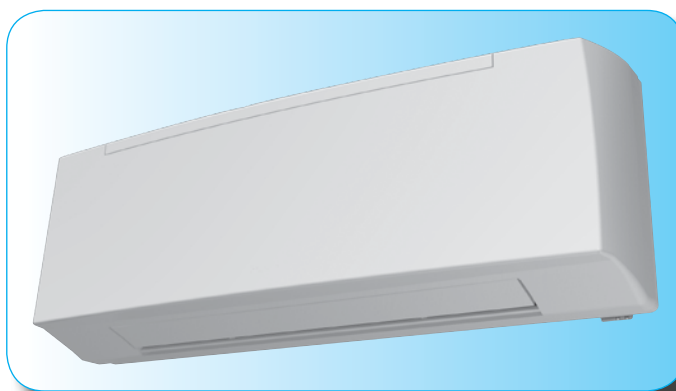

INSTALLATION
EXAMPLE WITH
INFRA-RED REMOTE
CONTROL

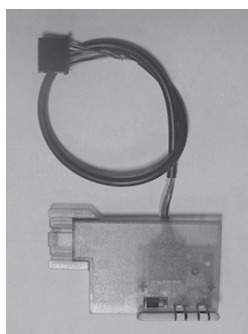

ID	Code
RS-RT03-F	9025301

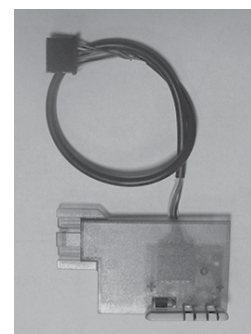

ID	Code
RS-F	9025300

A group of **FHW** units with **MB** electronic board can be connected via a serial link and can consequently be managed at the same time by just one **T-MB** wall control or **RT03** infra-red remote control. Using the special jumper present on the MB board, one unit must be configured as the master, and all the others as slaves. The remote control must be pointed at the receiver on the master unit. To avoid problems, it is recommended to install and connect the receiver only on the master unit.

With T-MB wall control

One control for each unit
(MAXIMUM LENGTH OF THE CONNECTION CABLE = 20 m)



One control for more units
(20 units max.)
(MAXIMUM TOTAL LENGTH OF THE CONNECTION CABLE = 800 m)

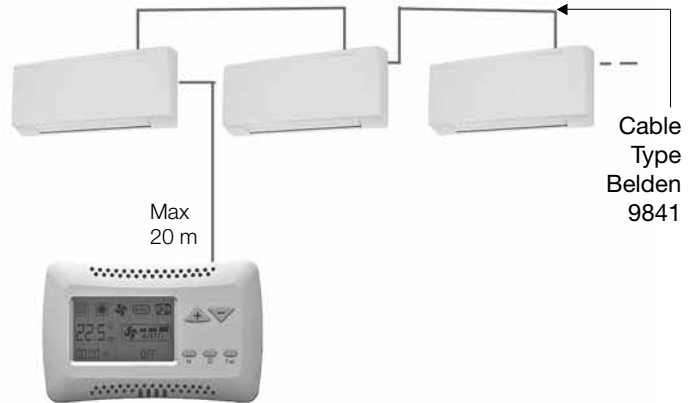

With RT03 infra-red remote control

One control for each unit



One control for more units
(20 units max.)
(MAXIMUM TOTAL LENGTH OF THE CONNECTION CABLE = 800 m)

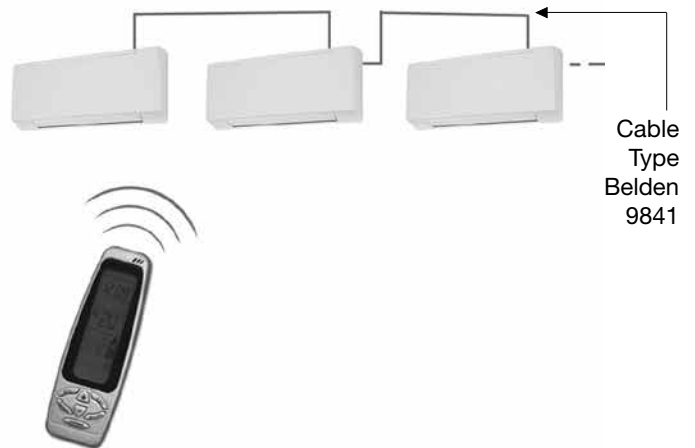

T2 accessory for units with infra-red remote control and/or MB electronic board

ID	Code
T2	9025310



T2 sensor to be placed on the water supply pipe upstream 3 way valves (not to be used with 2 way valve). The **T2** sensor must be used as described below:

- Change-Over for the automatic switch of the operating mode. If water temperature is lower than 20°C, cooling mode is set; on the other hand, if water temperature exceeds 30°C, heating mode is set.
- It can be used on units with electric heater and hot water supply. The **T2** priority probe activates the electric heater or water valve, depending on the water temperature detected. If water temperature exceeds 34°C, the water valve ON-OFF control is activated; on the other hand, if water temperature is lower than 30°C, the electric heater is activated.

PSM-DI Multifunction control panel

Description	ID	Code
Multifunction control (to be used with MB board only)	PSM-DI	3021293

Another option available for the serial communication between the units is the possibility to connect up to 60 **FHW** units in series and manage them with just one wall mounted **PSM-DI** controller.

The wall mounted controller can be used to set the operating mode for each individual unit connected, display the operating conditions of each individual unit, and set the ON/OFF time sets for each day of the week (the program can be set for all the units and for a maximum of two groups of units).

If more than 60 units need to be connected, two or more controllers must be used. Each unit must have a MB board.

The **PSM-DI** control is used to manage a series of fan coils, up to a maximum of 60 units (the maximum length of the RS 485 connection cable must not exceed 800 m), from one single control point.

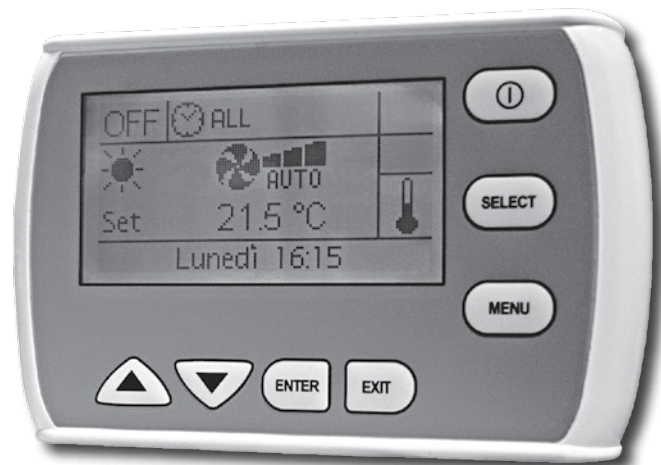

The **PSM-DI** control communicates via a serial line with all the units connected, with the possibility of controlling them all together or individually. In fact, the unique address of each individual fan coil means that all the units can be called at the same time, or the individual unit called, to perform the following functions:

- display the current operating mode, the fan speed, the set point;
- display the room temperature measured on the individual unit;
- turn all the units ON and OFF at the same time or alternatively each unit individually;
- change the operating mode (fan only, heating, cooling, automatic changeover);
- change the set point;
- modify the values and operation parameters of the fan speed.

Each function can then be sent to all the units connected, or alternatively to each individual unit.

Different set points or operating modes can be set for each individual unit.

The **PSM-DI** panel can also be used for the time management of the units over the week. Four ON times and four OFF times can be set on the units for each day of the week. A different Temperature set that will be considered as Operation set for all connected appliances, can be set for each event. If the Temperature set is not entered for the individual event, it must be set during programming for each individual unit or for the entire network.

Units without receiver or with receiver can be connected within the network: the former can receive instructions only from the **PSM-DI** wall mounted panel; while the latter can receive information from both the wall mounted panel (**PSM-DI**) and infra-red remote control. Use the infra-red remote control to force ON mode of the individual unit, if ON/OFF daily time programming has been set. The unit will regain the settings from the **PSM-DI** panel during execution of successive start-up program.

The PSM-DI panel cannot be used together with the NET management program (see next page).

Note: set the configuration Dip Switches of each fan coil as illustrated in the remote control use manual, based on the required solutions.

Note: the RS 485 network's overall length must not exceed 700/800 metres.

NET program for managing a network of FHW MB fan coils

Description	ID	Code
Hardware/software supervisory system (to be used with MB board only)	NET	9079118

NET is a centralised control system for networks of FHW MB fan coils, based on software that runs on LINUX™ operating system (the program is provided pre-installed on a PC).

The **NET** software offers a practical and economical solution for managing the units, with the simple click of the mouse.

The main characteristics include simplicity of use, an extremely complete and functional weekly program, and the possibility to access the historical operating data for each individual unit connected.

The program exploits all the potential of our units with remote controls, representing an addition to the latter.

The **NET** program is a control tool that can be used as a replacement for the remote control, or in parallel, however the settings made using **NET** can have priority over those made using the remote control.



The program can be used to:

- Create uniform groups (groups of units on individual floors, in offices or rooms).
- Save weekly programs configured for different types of operation (summer, winter, mid seasons, closing periods etc.); these can then be recalled and activated with a simple click of the mouse.
Weekly on/off cycles can be set for individual units or groups of units.
- Set the operating conditions for each individual unit or groups of units (operating mode, fan speed, temperature setting).
- Set the set point limits for each individual unit or groups of units.
- Switch each individual unit or groups of units ON or OFF.

The main program screen can display and interact with the entire network of units. An individual unit, a group of units or the entire network can be called so as to make modifications to the operating mode and the set point. The user can then check the operating status of each individual unit, read the room temperature, the coil temperature and the operating status of the condensate drain pump or any alarms.

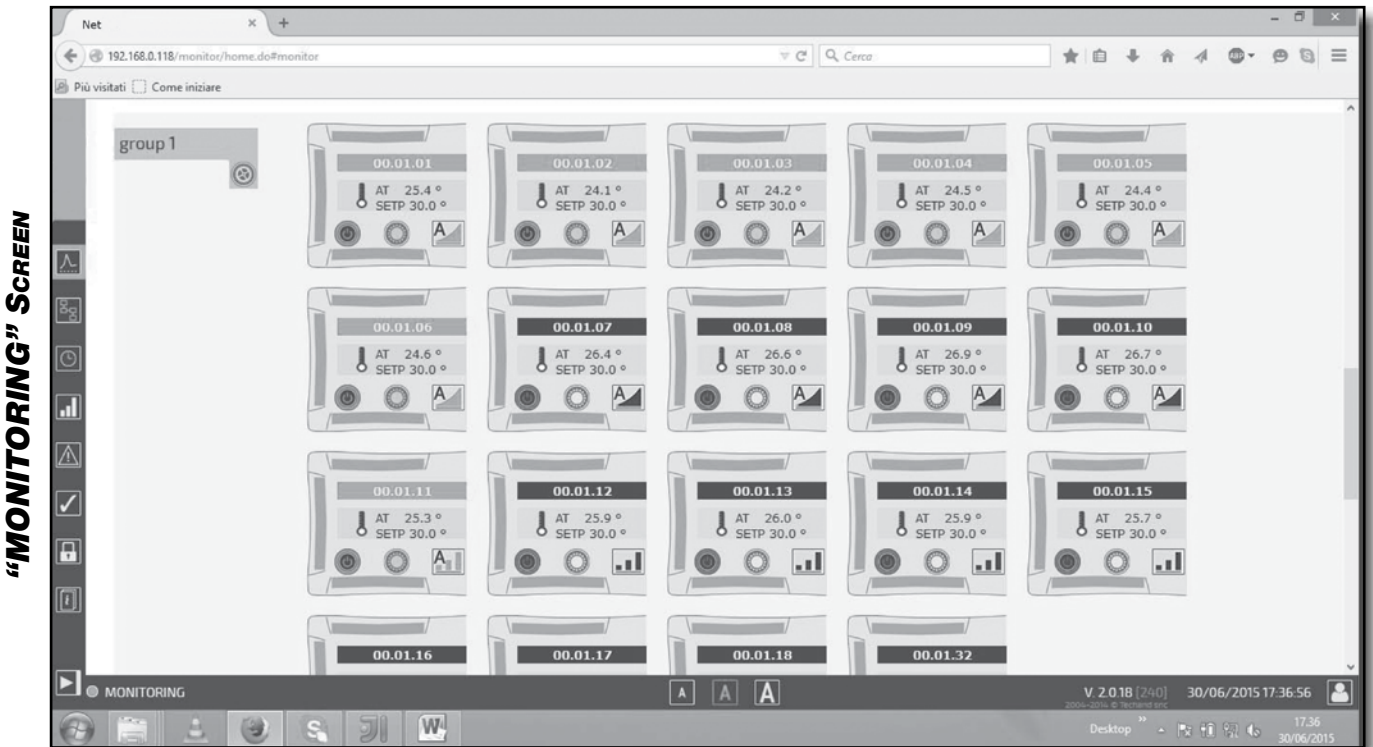

Displaying a unit

The "MONITORING" screen shows the units that are connected to the network and scanned by the program.

The icon of the terminal unit provides the following information:

- Unit name (**00.01.01**)
- Set temperature (**SETP**)
- Room temperature (**AT**)

- Unit status: **ON** (Green) **OFF** (Red)

- Mode: Summer Auto Winter Fan only

- Fan speed: Low High Medium Autofan

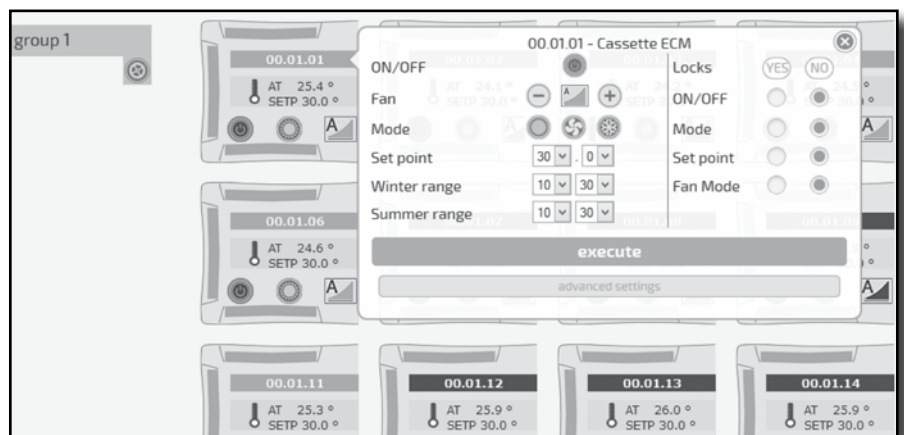

The “Weekly Program” can be used to set the unit operating parameters for each day of the week. Up to 20 different weekly programs can be set.

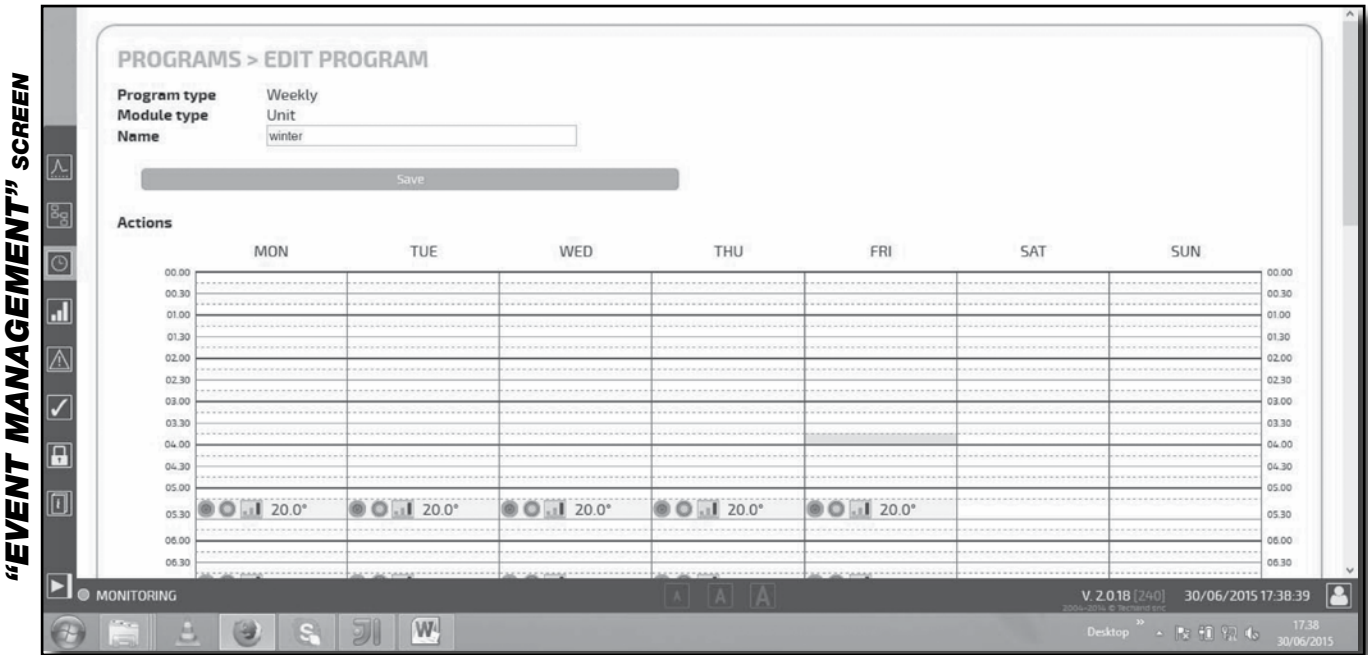

Time bands are available for each day of the week. The time and the type of operation to be performed by the unit can be set for each band. The time and the operating parameters can then be displayed before being sent to the unit and implemented.

PC NET Software

Connection of a FHW network MB versions

Legend

- U** = FHW unit
- I** = Power input
- O** = Outputs for systems
- J** = MC2 jumper to close. Network end.
- N** = 60 units max. (*)

- (*) In the event of more than 60 units, add one or more Router-S (see below).

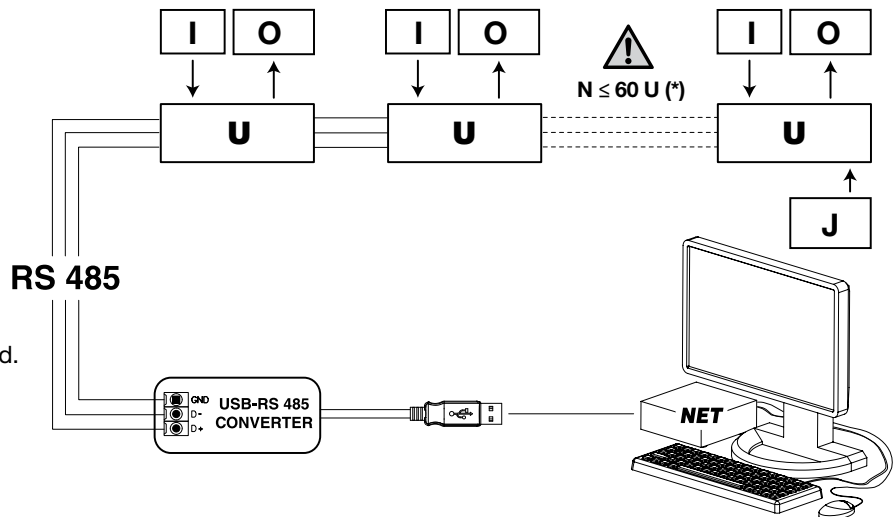

RS 485 serial connection cable

Shielded cable to be used:

Belden 9841, RS-485, 1x2x24 AWG SFTP, 120 Ohm

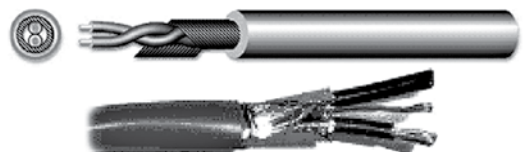

ID	Code
SIOS	3021292

SIOS is a board equipped with 8 relays with potential free contact to control the activation or deactivation of remote electric utilities. Moreover, the board has 8 digital inlets to display the actuators or external consents, such as motor or other. The SIOS boards can be connected:

- inside a network managed by NET;
- to a PSM-DI panel (one SIOS for each PSM-DI panel).

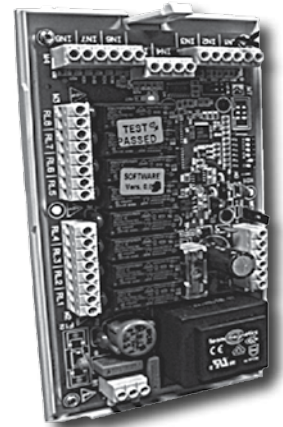

ID	Code
Router-S	3021290

The **Router-S** is an electronic board that:

- allows creating networks with more than 60 units (minimum 2 Router-S are required) or to divide the network (per floor, building, etc.);
- allows creating a Master/Slave sub-network to be controlled as an independent group.

The Router-S can be used only inside a network managed by NET.

- The number of Router-S to be used is:
- up to 60 units: no Router-S
 - from 61 to 120 units: 2 Router-S
 - every 60 subsequent units: 1 additional Router-S.

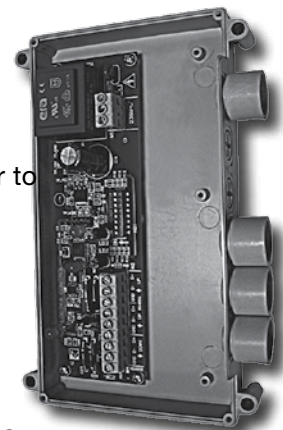



The descriptions and illustrations provided in this publication are not binding: we reserve the right, whilst maintaining the essential characteristics of the types described and illustrated, to make, at any time, without the requirement to promptly update this piece of literature, any changes that we consider useful for the purpose of improvement or for any other manufacturing or commercial requirements.



airconditioning & klimaatbeheersing

InterClima B.V.
Postbus 10
5430AA Cuijk
tel. 0485 - 350033
mail. info@interclima.nl

FHW - 09/15
COD. A4250170 E/09/15